

# Unico

**USER MANUAL**





Quality makes the difference.

Thank you for your trust and your choice of a Unico fireplace insert. We are convinced that it will fully meet your expectations both in terms of aesthetics and energetic parameters of the insert.

In order to make the most of the technical parameters of the Unico insert, as well as to ensure perfect safety during its use, we kindly ask you to read carefully and follow the instructions in this manual.

We wish you many years of trouble-free use of the Unico insert and countless happy moments spent in the warmth of the fireplace.

A handwritten signature in black ink, appearing to read "Waldemar Wuczyński". The signature is fluid and cursive, with a large loop at the end.

President of the Board  
*Waldemar Wuczyński*

1.	General information and recommendations	4
2.	Compliance with standards and regulations	4
3.	Safety recommendations	4
4.	Insert installation manual	5
4.1.	Fire protection	5
4.2.	Ventilation	6
4.3.	Combustion air supply	6
4.4.	Heating air circulation	6
4.5.	Chimney	6
4.6.	Connecting the Nemo insert to the central heating system	7
4.7.	Notes on the first start-up	8
5.	User manual	8
5.1.	Fuel	8
5.2.	Fuel feeding and firing up	9
5.3.	Burning	9
5.4.	Regulations	9
5.5.	Cleaning the insert	10
6.	Notes	11

### 1. General information and recommendations

The Unico Dragon fireplace insert is designed and manufactured in accordance with the latest trends and requirements for this type of devices. It is not only a decorative element of the apartment, but also constitutes an efficient source of heating that ensures proper thermal comfort of the building at relatively low operating costs.

The requirement for proper heating, satisfactory aesthetic impressions, and, above all, operational safety of the Unico fireplace insert, is strict compliance with these instructions. If the user fails to do so, the warranty on the insert will be void, and the user will bear all consequences for improper operation.

Never carry out any repairs or modifications of the insert yourself, or the warranty will be voided.

### 2. Compliance with standards and regulations

Any installation, operation and maintenance works on the insert must be carried out in accordance with the provisions of all applicable national and European standards:

- PN - EN 13229:2002 as amended: PN - EN 13229/A1:2005, 13229/ A2:2006, 13229:2002/AC - fireplace inserts with open fireplaces for solid fuels, requirements and tests.
- Ordinance of the Minister of Infrastructure of April 12, 2002 on the technical conditions required for buildings and their location (Journal of Laws No. 75 item 690)
- Ordinance of the Minister of Infrastructure of March 12, 2009 on the technical conditions required for buildings and their location (Journal of Laws No. 56 item 461)
- Other national and local provisions should also be complied with.

### 3. Safety recommendations

Unico fireplace insert is a device that is completely safe, and provides satisfaction and joy of use when installed and operated in strict compliance with safety requirements.

Please pay special attention and follow the recommendations below:

- The insert should be installed and commissioned by a specialist company with the appropriate qualifications, experience and tools.
- The insert can be used when it, as well as the entire installation, is in perfect technical condition. Any operational malfunctions, damages and irregularities should be immediately reported to the installation company.

- The Unico insert is designed to work only with its door closed. Using the insert with the door open is prohibited.
- During operation of the device, all its components are heated, so any maintenance works should be carried out with the use of protective gloves.
- Any servicing or maintenance works can be carried out only with the fire extinguished.
- Tightness of the insert (tightness of the seals, proper operation of the air damper) should be checked on a regular basis (at least once a month).  
Proper operation of the ventilation system should be constantly monitored. In particular, negative pressure should be avoided in the room in which the insert is used. This is extremely important when using mechanical ventilation.
- The fireplace insert must be protected from children's reach.
- The room where the insert is installed must be equipped with a fire extinguisher.
- Use only original spare parts of the Manufacturer.
- Ensure regular maintenance of the insert according to the instructions.
- Use only the fuel recommended in this manual.

## 4. Insert installation manual

### 4.1. Fire protection

The fireplace should be installed on a smooth and even

surface after checking its load capacity, taking into account both the weight of the insert, as well as its housing. It is recommended to make a foundation for the fireplace that is min. 50 mm thick.

After mounting, the insert should be levelled with adjustable feet.

The floor around the fireplace must be made of non-combustible material, keeping the distances given below:

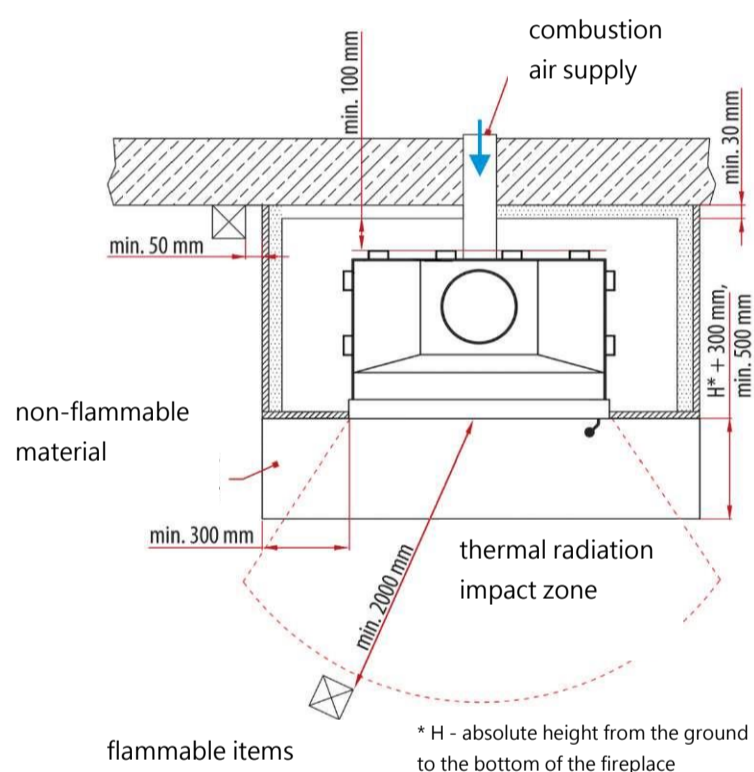

Fig.1

**Installation of the fireplace insert must be a self-supporting structure, without any direct connection to the insert. It should provide easy access to the insert and its connections for servicing and inspection purposes.** The housing of the insert should be insulated in such a way that its vertical and slanting surfaces do not heat up over 120°C, and the horizontal surface (shelves on which objects can be placed) - over 85°C.

The walls around the fireplace should be protected from heat by using insulation made of non-combustible materials.

The ceiling above the fireplace should be protected by making a decompression chamber from insulating materials. The minimum distances to be kept for the foundation and installation of the Unico fireplace insert are shown in Figure 1 and Table 1.

insert wall - room wall	10 cm
insert wall - insert housing wall	2 cm
insert floor - foundation	15 cm
air outlet grille - ceiling	60 cm
insulation material thickness - walls and ceiling	min. 3 cm
insulation material thickness - foundation	min 10 cm

Table 1.

Do not place any objects made of flammable materials on an insert without housing. It is absolutely necessary to keep the appropriate distance of flammable objects from the fireplace:

- min. 200 cm from the edge of the firebox in the radiation area
- min. 5 cm from the edge of the insert housing outside the radiation area

### 4.2. Ventilation

The minimum cubic volume of the room in which the fireplace insert will be installed should result from the indicator of 4 m<sup>3</sup>/kW of the nominal power of the insert, but should not be less than 30 m<sup>3</sup>. For optimal working conditions of the insert, proper ventilation of the room in which it will be installed should be provided. The necessary amount of ventilation air is 10 m<sup>3</sup>/h per 1 kW of nominal insert power. If other heating devices are installed in the room with the fireplace, ventilation should be provided so that the amount of air for all devices is sufficient and that they do not interfere with each other.

**NOTE:**

Extraction devices operating in the same room as the fireplace or in a jointly ventilated room can pose problems.

**4.3. Combustion air supply**

It is absolutely necessary to provide sufficient combustion air to the fireplace insert. In Unico inserts, this is done from outside the room through a suction unit.

The suction unit is equipped with a connector for the air duct with a diameter of 0 98 or 0 125, depending on the model, with the possibility of mounting it in one of three designated holes.



Fig. 2.

The section of the air duct that reaches and connects with the insert must be made of non-combustible materials (steel or aluminium sheet). **The use of plastic pipes (e.g. PVC), is strictly prohibited.**

The other end of the air pipe must be protected with a ventilation grille that must be cleaned regularly.

In the case of inserts with a lifted glass, it is recommended to provide an adequate convection air flow. Otherwise it may lead to an increase in the temperature in the fireplace chamber, and, as a consequence, damage bearings and other elements of the insert, as well as the fireplace housing.

It is recommended to protect the air intake from dust and sand from the outside, which may damage the air intake control mechanism.

**4.4. Heating air circulation**

For proper heat dissipation from hot elements of the insert and the pipe to the room, appropriate cross-sections of the heating air inlet and outlet should be provided.

The minimum area of the cold air inlet (at the base of the fireplace) must be 50 cm<sup>2</sup>/1 kW of power generated by the fireplace, assuming that the fireplace is used with convection.

The minimum surface of the hot air outlet grille (in the upper part of the housing) must be 40% larger than the surface of the inlet, assuming that the fireplace is used with convection. When using grilles with a mesh, the hole surfaces should be doubled.

For heat-storing use, the inlet and outlet grilles are individually selected depending on the amount of accumulated mass used.

Air grilles must be constructed in a way to prevent clogging.

**4.5. Chimney**

One of the most important elements of the fireplace insert installation is the chimney. Its proper performance often has a decisive impact on the smooth and safe operation of the entire system.

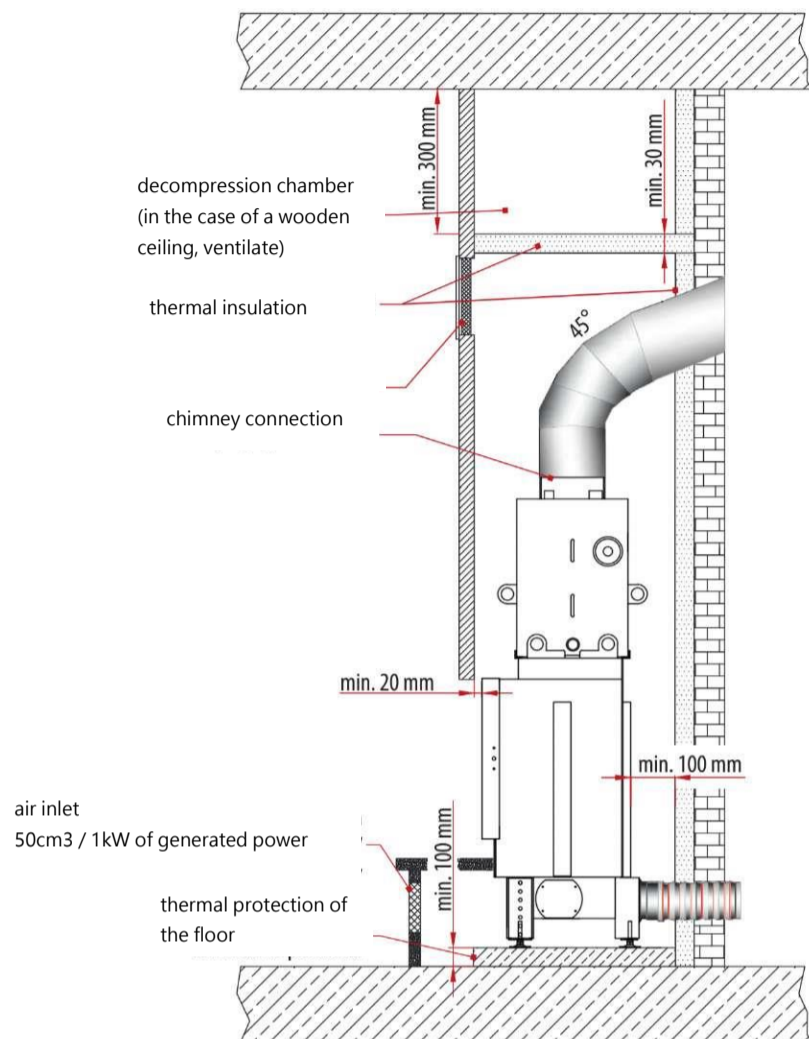

Fig. 3

Before installation, it is recommended to carry out a technical assessment and obtain an opinion from an authorized chimney cleaning company.

To connect the insert to the smoke duct, use a pipe made of certified heat-resistant sheet with a diameter equal or larger than the diameter of the outlet pipe of the fireplace.

To ensure proper draft and to prevent local sooting, it is recommended to use pipe elbows with a slope of max. 45°. The total height of the chimney must be min. 4m.

If the pressure in the chimney is insufficient (lower than the one in the table for the given model of the insert), a draft boosting device should be installed on top of the chimney.

#### 4.6. Connecting the Nemo insert to the central heating system

Fireplace inserts Unico with a water jacket can be used in gravity or pump heating open systems as an independent or supporting heating source. The installation should be secured in accordance with the requirements of PN-B 02413:1991.

##### a) Open system

- The maximum pressure of the installation should be 1.9 bar.
- An open expansion vessel should be connected with a pipe of  $\varnothing$  min. 28 mm.
- The expansion vessel must be located above the highest point of the installation, the overflow hole should be 0 1".
- If the fireplace insert is to be installed with another boiler operating in a closed system, a separating plate heat exchanger should be used.
- Regardless of the type of installation, air vents should be used in those places where there might appear air traps.
- The central heating installation should be made in such a way as to always maintain the temperature of water return to the fireplace above the dew point, i.e. approx. 50°C (e.g. by installing a thermostatic mixing valve ensuring an appropriate return temperature). This is a requirement for the warranty to be recognized in the event of the insert malfunction. This prevents the insert from humidity resulting from condensation, and hence from corrosion.

Dragon inserts are equipped with the so-called system

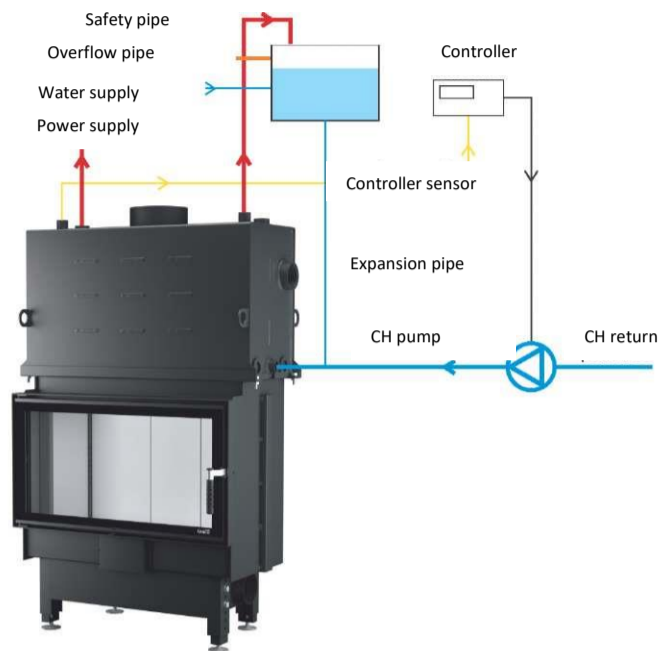

Fig. 4.

#### b) Closed (pressure) system

The Unico Nemo fireplace insert with a water jacket can be used in closed heating systems as an independent or supporting heating source. The installation should be made and secured in accordance with the requirements of PN-EN 13229/A1:2005, 13229/A2:2006.

- The maximum pressure in the installation system should be 1,9 bar.
- A diaphragm expansion vessel should be used.
- The insert should be secured by a 2.0 bar safety valve.
- The Unico Nemo fireplace insert should be equipped with a water jacket cooler (coil) and a thermostatic safety valve.

#### NOTE:

- In order to facilitate installation, Unico Nemo fireplace inserts are equipped with connections for installation on both the right and left side of the body.
- It is recommended to install fireplace insert accessories, such as pump, valves, heat exchanger, expansion vessel, etc., so that they are visible and easily accessible.

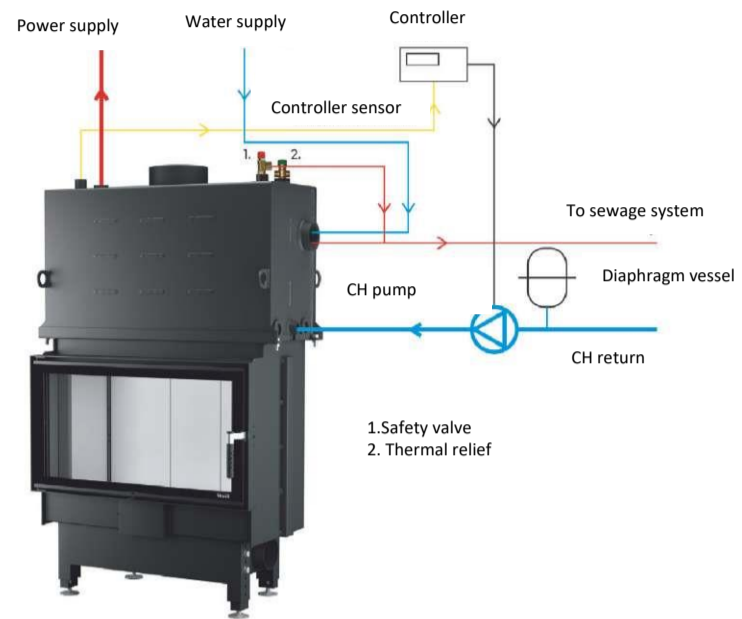

Fig. 5.

#### 4.7. Notes on the first start-up

- The first start-up of the insert must be made before installing the fireplace.
- After the first usage of the insert, a check should be made whether the central heating installation is filled with water.
- If there is a risk of temporary temperature drop below 0°C, the central heating installation should be filled with anti-freeze liquid.
- The use of corrosion inhibitors is recommended.
- During the first few hours of burning, the varnish coating is burned out and, as a consequence, there might be a specific, often unpleasant smell.
- Before the first use, the gaskets (in the upper part of the chamber) used for protection during transport must be removed.

## 5. User manual

### 5.1. Fuel

- The fireplace is designed for burning natural wood with humidity not exceeding 20%.



The best fuel material are burning logs of high density hardwood (over 500 kg/m<sup>3</sup> whose calorific value equals about 2100 kWh/m<sup>2</sup> - such as beech, ash, oak, hornbeam.

- Wood should be stored outdoors, in a dry and well-ventilated place.

It is not recommended to burn coniferous wood in the fireplace for a long time because of the resins it contains, which can quickly lead to burdensome soiling of the insert. In addition, softwoods are prone to sparks, which can at times be dangerous due to the possibility of sparks flying into the room when opening the door.

- It is prohibited to burn any materials in the fireplace that are not natural wood waste, in particular: chipboards, varnished or stained wood, cardboard and paper, all kinds of fabrics and plastics.
- It is prohibited to burn or otherwise use flammable liquids.

## 5.2. Fuel feeding and firing up

- a) Check whether the supply and extraction air systems are not blocked.
- b) Before loading fuel, clean the firebox of excess ash, but not completely. Move the remaining ash under the rear wall of the firebox to allow primary air to enter the chamber from under the front strip.
- c) Place thicker wood logs at the bottom of the firebox. Gradually place increasingly smaller logs and top them with finely chopped logs and kindling. Kindling (preferably rolls of wood wool soaked in paraffin) should be put on top of the pile and lit from the top, which is the recommended method for Unico inserts, making burning cleaner with less smoke emission, which, in turn, makes the whole process more ecological and efficient.
- d) Open the combustion air inlets completely.
- e) Set fire to the kindling and leave the door slightly open until the fire does not fade anymore after closing.
- f) Do not use any liquid kindling, gasoline, thinners, etc. for the fireplace.

## 5.3. Burning

- a) When the first load is burnt out and only embers remain, you can add wood as needed to match the size of the insert.

You should take into account that from burning 1 kg of wood we obtain about 3.4 kW, so no more than

4.5 kg of wood should be put into a 15 kW insert. Adding larger amounts of fuel at one time may damage the insert.

- b) Logs should be placed as much as possible to the back of the firebox, so that during burning and sliding they do not adhere to the glass and fall out when opening the door.
- c) The door should always be opened slowly in order to prevent negative pressure and the gases escaping into the room.
- d) The intensity of combustion is controlled with the adjustment slide.

## 5.4. Regulations

- Combustion air regulation

Primary air for combustion is supplied from outside to the collector installed underneath the insert. A special regulation system delivers it to the upper and lower part of the firebox.

- Afterburning system

Extreme positions of the lever allow to completely shut off or open the primary combustion air supply.

Each lever position in between allows to supply the appropriate amount of air to the upper and lower parts of the firebox according to demand.

The Dragon inserts are equipped with the so-called afterburning system. Special channels (permanently open, not adjustable, except for the use of a controller with an automatic air damper) supply air to the slats in the corners of the rear wall. This enables the combustion of unburned gas residues, thus improving both the efficiency of the insert and the cleanliness of combustion.

#### Air supply regulation

- Position 1 - max. to the left - the air is directed to the firebox floor and the door - the most intense burning.  
Position 2 - in the middle - the air is directed only above the glass - reduced power. Recommended position for the insert.
- Position 3 - max. to the right - the primary air is completely shut off - operation in support when the wood is burnt and only embers remain.  
Note: the glass easily gets dirty in this position.

Pozycja 1



Pozycja 2



Pozycja 3



The air opening direction is indicated by the symbol on the bar as shown in the diagram below

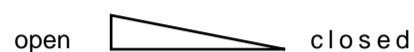

#### 5.5. Cleaning the insert

Systematic cleaning and maintenance of the fireplace insert is required for its safe and proper operation, and also affects its aesthetic appearance.

How to clean the insert:

- remove excess ash from the firebox chamber
- clean the walls and shelves in the upper part of the firebox chamber from soot and other impurities
- clean the glass

Cleaning should be carried out only with the fire put out and the firebox cool, using protective gloves.

Ash should be removed with a scoop and thrown into a metal container with a lid or collected using a fireplace vacuum cleaner.

Wall surfaces inside the combustion chamber should be cleaned using a soft brush, and if there is soot - a spatula.

The fireplace glass should be cleaned with a special Unico sponge - the material that the sponge is made from can remove the most stubborn soot dirt. It can be ordered at: [gabka@unico-kominki.pl](mailto:gabka@unico-kominki.pl) +48 74 832 46 90

#### NOTE:

Using chemicals that can run down the gasket significantly shortens its life (due to built up scale) and can lead to damage (cracking) of the fireplace glass.

Before the start of the heating season, a comprehensive inspection of the insert should be performed and the following points should be checked:

- any blockages and tightness of the ducts supplying combustion air, cleanliness of the chimney and its connections,
- the quality of the gaskets (it is recommended to replace them with new ones),
- the condition of ceramic plates inside the firebox - in case of noticeable defects it is recommended to replace them with new ones. If there are cracks, there is no need to replace the ceramic components, as it does not affect the operation of the fireplace.

#### **6. Notes**

- a) Never use the fireplace insert with the door open.
- b) Take proper care if there are children in the room where the fireplace is used. The glass temperature can often exceed 300°C, which, when handled carelessly, can cause burns or fire.
- c) In case of any malfunctions or if you need to put out the fire, close the air intake damper. If this is not enough, use a spatula to collect the contents of the hearth into a metal bucket and take it outside the building.

**Under no circumstances should you put out the fire with water!**

- d) The fireplace insert housing should be designed and made in a way as to allow any assembly and disassembly of the entire insert or part of it without the need to damage it.
- e) When installing the insert with the PowerLIFT lifting glass, it is advisable to place inspection grilles at the height of the bearings.

**Unico**

**Producent Unico**

Unirol Sp. z o.o.

ul. Wrocławska 2a

58-211 Uciechów

tel. +48 74 832 46 90

tel. +48 74 831 00 50

e-mail: [unico@unico-kominki.pl](mailto:unico@unico-kominki.pl)

[www.unico-kominki.com](http://www.unico-kominki.com)